

ELECTRONICS

P. C. Electronics 2522 Paxson Lane Arcadia CA 91007-8537 USA ©2000

Tel: (626) 447-4565 m-th 8am-5:30pm pst (UTC - 8) Tom (W6ORG) & Mary Ann (WB6YSS) O'Hara

24 hr FAX order line (626) 447-0489

Email: tomsmb@aol.com

Web site: <http://www.hamtv.com>



TVCX-23 & TVCX-12

Crystal Controlled 23 cm ATV Downconverter Board

The TVCX-23 is a wired and tested downconverter board designed to convert the ATV signals in the 23 cm amateur band (1240-1300 MHz) down to TV channel 10 (193.25 MHz), 45.75 MHz TV IF or 70 MHz FM IF. Conversion gain is ≥ 15 dB which is more than enough to drive a TV, or the P. C. Electronics VRC45b ATV receiver module to the noise floor. FM ATV with the HFT IF70 needs 10 dB more system gain preferably with an antenna mounted preamp for most sensitivity. The intended primary use is with ATV repeaters, links, or anywhere there will be unattended operation and ambient temperature variations requiring crystal control. TVCX-12 is the board ready to go in a diecast aluminum box. A second crystal may be switched in by grounding a relay lead as long as the input frequency difference is no more than 24 MHz.

The NE25337 dual gate GaAsfets in both the RF preamp and mixer stages plus a triple tuned bandpass filter gives good resistance to frontend overloads. This wide dynamic range is especially necessary at shared repeater sites or base stations running crossband duplex. For duplex, ant. driven elements end to end separation must be > 5 ft.

The TVCX-23 comes tuned up for the customers specified input and output frequency. The crystal formula, and various inductors and capacitors are different depending on the output frequency. For CH 10 or FM IF the mixer takes low side injection to maintain the same vestigial sideband into the TV set [$F_{xtal} = (F_{23cm} - 193.25) \div 70$]. If channel 10 is used in your area, a crystal for ch 11 (199.25 MHz) can be special ordered. The LO injection to drive a standard AM video receiver IF takes high side injection to invert the vestigial sideband [$F_{xtal} = (F_{23cm} + 45.75) \div 12$]. The crystals are all 5th overtone types in a HC-25 case. If the input frequency is changed, the LO chain can be repeaked using a DC voltmeter at the emitter resistor of the stage following the trimmer caps that are being adjusted with an insulated tuning tool.

BOARD MOUNTING: The TVCX-23 must be mounted in a shielded enclosure to prevent strong broadcast signals from adjacent channels or other nearby transmitters from putting interference into the picture. The L.M.B CAB 234 (TVCX-12) is a good RF tight enclosure for the downconverter when its output is for TV channel 10. The TV output from the board can then be a short single hook up wire to a type F61 chassis connector.

The antenna input should be a BNC or type N chassis connector connected with a short length of small coax such as RG174. Cut and dress the coax so that the center conductor is not out of the shield more than 1/4". Fold back the braid on the outer insulation. Ground this braid both at the board ground plane, and directly solder to the connector shell close to the center.

Mount the board with four 4-40 x 1/2" machine screws and nuts as shown. The +11 to 14 Vdc @ 50 ma can be run thru a feed thru capacitor or a coaxial type connector with a short leaded 10pf and .01mF soldered directly on it and ground. Externally a 1/4 amp fuse must be in the + line to prevent damage due to reverse polarity or greater than +15 Vdc.

The 45.75 MHz IF version can be mounted in the L.M.B CAB 247 box along with the VRC45b module for a complete receiver. The ATVR-12 receiver is this combination built, tested and ready to go. If other TV IF strips are used a suitable enclosure must be found, and also an additional AGCed IF amplifier may have to be added to make up for the required system gain and AGC range similar to that found in the VRC45b module. For repeaters, use double shielded RG55 between the VSB filter and the downconverter to prevent desense from feed-around.

OPERATION: If at first you do not receive any ATV signals, do not be tempted to start tweaking the trimmer caps. Your board comes tested and peaked for your specified input and output frequency, but stray capacity to your chassis, handling, or shipping vibration, could detune it slightly. Make sure a known close-by station is on the air with your antennas pointed at each other, or use a signal generator with about 200 microvolts output connected. Peaking on a slight snowy picture can be done with an isolated DC voltmeter on the TV sets video IF AGC (not the RF AGC and take care not to touch the TV chassis at the same time as you do the TVCX-23 if the TV's chassis is hot to the AC line) or at the VRC45b's AGC test point. But first fine tune the TV tuner on channel 10 with the TVCX-23 power off for minimum adjacent channel interference. Turn the downconverter on and peak C1 thru 5 slowly and carefully with an insulated tuning tool.

Before putting up the 23 cm antenna, determine the local antenna polarization preference. The 2424LY can be mounted either way. Horizontal is preferred by those also running CW, SSB, and weak signal DX work. Vertical is preferred by those on FM or who want to easily get good omnidirectional gain antennas such as the Diamond F1230A for repeaters or public service work. 23 cm will go 1/3 the distance 70 cm will for the same power, antenna gain, coax loss, etc.. Therefore it is extremely important that good resonant 50Ω antennas placed as high as possible be used. Belden 9913 coax is suggested with N connectors put together properly and moisture proofed (see ARRL Handbook). Coordination on a 2 meter simplex channel is strongly suggested for fine peaking adjustments, talking in beam headings, picture quality, etc.. The ATV transmitting station talks on the sound subcarrier which comes thru your TV sets speaker. At the same time all the receiving stations can talk back on 2 meters. You can also run full duplex ATV with another station on 70 or 33cm.

If your 9913 50 Ohm coax run is more than 50 ft and for the last little bit of sensitivity on AM, or receiving FM ATV with the HFT IF70 or other FM receiver, we suggest placing a Downeast Microwave 23LNAWPQ antenna mounted preamp at the antenna. However the preamp does not have T/R switching provisions - no transmitting through it. The preamp can be powered thru the coax as shown from the TVCX-23 board by adding a 10 pF cap and 100 ohm resistor. Before connecting the 9913 coax to the preamp, verify the +12 to 18 Vdc presence at the coax center pin with a voltmeter. Then tape or use coax seal around the preamp N connectors. Do not connect to the antenna coax without the preamp in line to an antenna that has a dc short or you could burn out the 100 ohm resistor or blow a fuse.

©2000

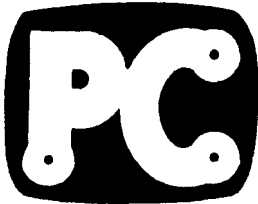

TVCX-23 & TVCX-12 ELECTRONICS Crystal Controlled 23 cm ATV Downconverter Board

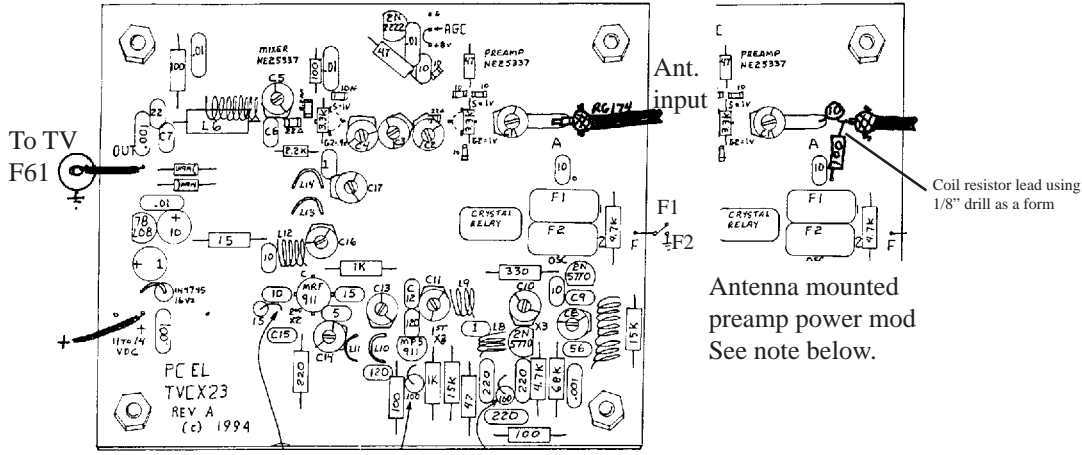

X2 > 3 Vdc TP X3 > 4 Vdc TP Osc. > 5Vdc TP
 Peak C13 & 14 Peak C10 & 11 peak C8
 If you change crystals, repeak each trimmer cap using a insulated tuning tool and monitoring on a DC voltmeter starting at the oscillator.

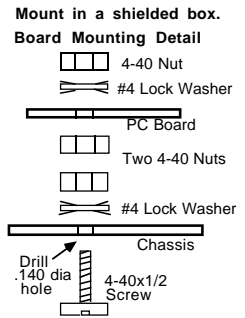
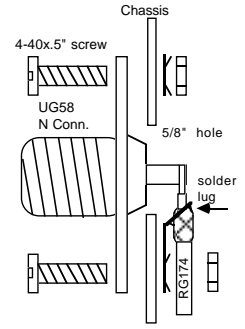

Antenna mounted preamp power mod
 See note below.

TVCX-23 rev A Board Notes

Trouble Shooting: check all coax and power connections. Moisture in coax? Rotor calibrated? TV on channel 10? Station actually on the air - ask on 2 meters or try receiving a different station? Check your fuse. Check external power supply voltage and polarity. TVCX-23 board voltage checks: 8 Vdc out of the 78L08 regulator? Preamp and mixer source leads 1 Vdc +/- .5V? Preamp Gate 2 Voltage same as source? Mixer Gate 2 40% of source voltage? TV out 1N914 protection diodes OK? See service policy on the ordering page in the catalogue if you give up and want us to repair it.

RF AGC (optional) the jumper can be removed for manual RF gain and 3 leads run to an external 10K pot. This will vary the preamp from 0 to 8 Vdc to reduce strong signals as may be found during demos or public service operations. Also if used with the VRC-45B IF / receiver module, a wire is run to it's RF AGC test point for wider dynamic range.

Antenna Preamp Power through the coax can be done externally with the model APA adapter, or internally by putting a 10 pF in series with the antenna input center coax lead. Also add a 100 ohm resistor, coil resistor lead using a 1/8" dia drill as a form. Check for shorts with an ohmmeter before turning on power. Normal voltage drop is 2V across the resistor. Caution: if you later use the TVCX-23 without the antenna mounted preamp connected for portable, mobile, etc., disconnect one of the 100 Ohm resistor leads as the loop Yagi and other antennas are DC shorts. ©1998

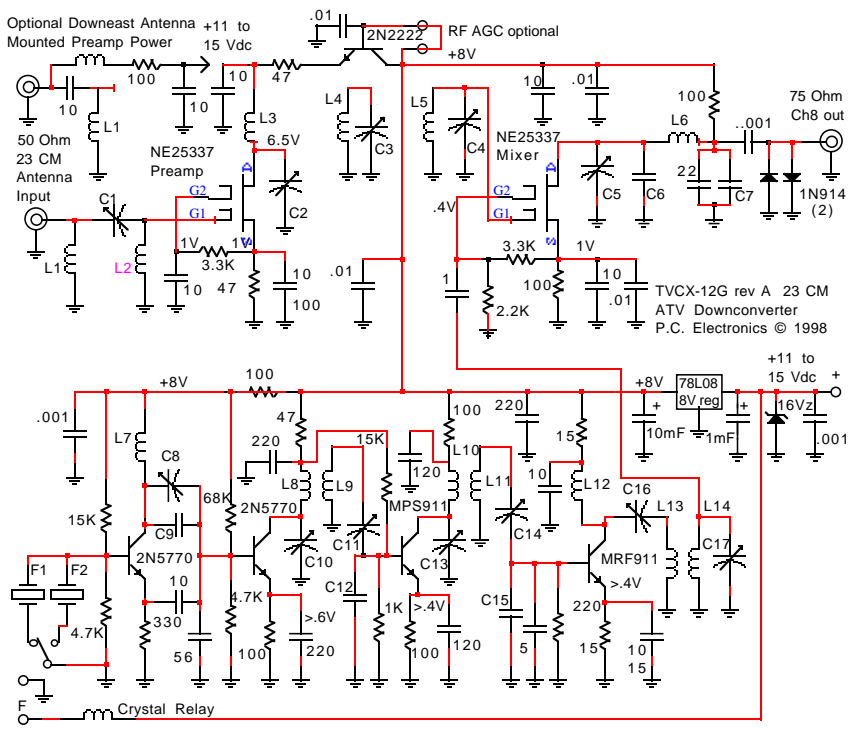

Output frequencies:
 Standard is ch 10 (193.25 MHz). Other outputs are optional with an LO readjustment and parts change.

Fout	C6	L6	C7	C9	C12	C15
ch10-193.25	0	8.5T	5	22	15	5
ch3 - 61.25	5	.47uH	0	0	15	5
70 MHz	0	.47uH	10	0	15	0
45.75 MHz	5	.68uH	5	5	10	0

Directive Systems 2424LYRM
 Loop Yagi - Vertical Polarization

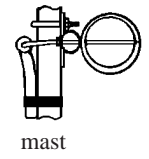

Horizontal Polarization

