



TXA5-70S-33cm ATV Transmitter Board

The TXA5-70S size was made at 2.1 x 4 inches to fit a standard model rocket diameter, accommodate most R/C aircraft, portable applications as well as being packaged in a CAB234 box with a FMA5 sound board. The board comes soldered and tested. The standard US 33cm band ATV frequencies of 910.25, 911.25, 913.25 and 923.25 MHz are selected by an on board digiswitch or external rotary switch. Non-standard frequencies can be special ordered. It is strongly suggested in order to minimize interference, that only those frequencies be used that are coordinated for ATV or by local band plan. Check with local ATVers.

The video modulator has an adjustable sync stretcher circuit that accurately sets the 70%-30% video to sync voltage ratio to compensate for any non-linearities in the video source, exciter or add on amplifiers, regardless of average picture level changes or video gain control adjustments. See modulated video waveform sketch.

The RF section uses a voltage controlled oscillator (VCO) locked on frequency by a crystal referenced synthesizer. This keeps RF energy out of the range of the R/C receivers below 75 MHz and 2 meter voice coordination channels. The VCO is followed by an isolation amplifier and an AM modulated final amplifier. Power output is 50 to 100 milliwatts p.e.p. which will give a simplex DX of 1/8 mile dipole to dipole or up to 3 miles with beams line of sight. The output power is also adjustable for directly driving the DEM 3310PA to 10 Watts.

DC POWER INPUT: Power requirement is 8.0 to 11 Vdc @ 200 ma direct or +12 to 14 Vdc through a 22 Ohm 2 Watt resistor. Do not exceed 14.0 Volts, and make sure of supply polarity before applying. Run #22 wires from the battery or regulated power supply through a 1/2 amp slow blow fuse to the solder pad marked "+" and the negative lead to an adjacent pad in the ground foil or common chassis ground. The DC power input goes through diode to a 5 Volt regulator on the board.

VIDEO INPUT: The board accepts any composite video source (1 volt peak to peak, negative going sync into 75 Ohms). This is standard from most all US cameras. Twisted #22 hook up wire can be used for runs up to 4 inches long, otherwise use small coax of any kind for up to 10 ft, or 75 Ohm coax for anything longer. The center conductor goes to the "V" solder pad and shield to the adjacent ground foil. The video gain pot can be removed and replaced with a 100 ohm carbon panel pot (available from us - do not use wirewound types) and 3 wires.

AUDIO SUBCARRIER INPUT: This is optional if you also want sound. Use a short direct length of small coax from the FMA5 Sound Subcarrier Board with the center lead to the TXA5-70S "S" solder pad and braid to the ground foil.

RF OUTPUT: The board comes with the proper blanking pedestal power setup (red mark). The power and pedestal will have to be readjusted to drive the 3310PA amplifier.

It is very important for normal operation as well as preventing the final amplifier from blowing, to have a low VSWR antenna/load. No more than 10% reflected power is acceptable. Take special care with all RF cable, connectors and the antenna. Small RG174 coax center conductor can be soldered to the RF output pad (A) on the bottom of the board and it's shield directly to the adjacent ground foil. See sketch for connecting the other end to a BNC chassis connector.

VIDEO GAIN: Apply video with a well lit white spot or area that occupies at least 10% of the picture and adjust the video gain 100 Ohm pot (VID) to the point where the white area just begins to smear or white out, then back down a little. Monitoring on your own TV set can give a false or unstable picture due to overload or multipath reflections. If this occurs have someone 100 ft or more away talk in your adjustment over the local 2 meter ATV coordination channel. Excessive video gain results in a buzz or distortion in the audio since the white areas cut off the carrier and can create excessive sideband harmonics.

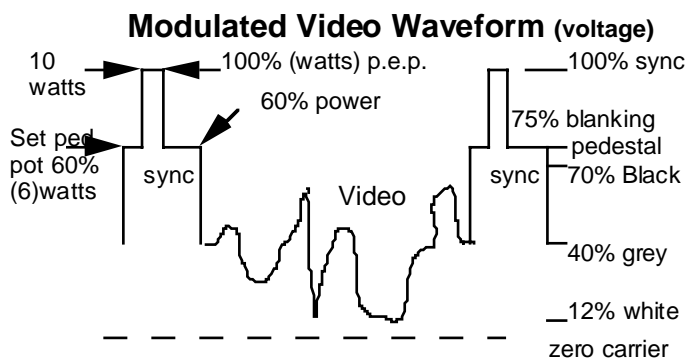

ANTENNA: This is the most important part of your video system. The antenna must be broadband and designed for the operating frequency for proper transmitter operation and best distance. The Directive Systems 3318LYARM loop Yagi is suggested for home use with its 14 dBd gain. Half of the loop Yagi can be used for portable and public service applications, R/C receive or demo's since the boom comes as two 3 foot sections. 3" quarter wave Whip type antennas need a minimum 6.5" dia. ground plane surface for best results. For R/C Airplanes, a 6" Dipole embedded in the tail fin works well - see R/C app note. Run RG 174 50 Ohm coax to it from the transmitter. Secure the coax at as many places as practical to minimize vibration modulation noise. Trim each side of the dipole in 1/8" increments for minimum VSWR, any close metal can affect the match. A vertical ground plane can also be made with a 3" whip sticking straight down (best) or up from the fuselage. The coax shield at that point should connect to some copper tape or wire 3.5" long running both directions horizontally along the fuselage. ©2004

ADJUSTMENTS:

For running the board by itself: The module comes tuned and set up for full output and should need no adjustment. If you suspect that the tuning or set up has changed due to handling, shipping, etc., then follow this procedure.

1. Disconnect any video and turn the pedestal pot (PED) full counter clock wise. Make sure that a low VSWR antenna or 50 Ohm dummy load is connected.
2. Referring to the layout drawing, connect a DC voltmeter to the RF Out test point and peak C2 & 3 for maximum. Then reset the blanking pedestal pot for 75% of that DC voltage at the RF Out test point - RF TP.

EXTERNAL AMPLIFIER: The RF Output and blanking pedestal must be reset any time an external amplifier is connected. Only adjust the pedestal with no video connected. Turn the blanking pedestal pot (PED) to full counter-clockwise. With an external amplifier, a RF Wattmeter must be placed in the amp output coax line. This level is the peak envelope power or sync tip power. You can adjust the RF Level pot at this time for the desired output p.e.p. of the final amplifier and should not exceed 90% of the amplifiers rated maximum output. Make a note of this value. Next slowly rotate the blanking pedestal pot (clockwise) for 60% of the noted value. If you have a calculator, multiply the Watts by .6 for the proper blanking pedestal power level. Do not touch the trimmer caps or RF Out pot after setting the pedestal.

MOUNTING: The board must be put in a shielded enclosure to prevent stray RF from getting into the camera, R/C receiver, and to provide a heat conduction/radiation path. The TXA5-70S-33 can be placed in a CAB234 chassis with a FMA5 sound board and optionally a TR-1 relay board - see TXA5-RC packaging application note.

Mount in a shielded box.

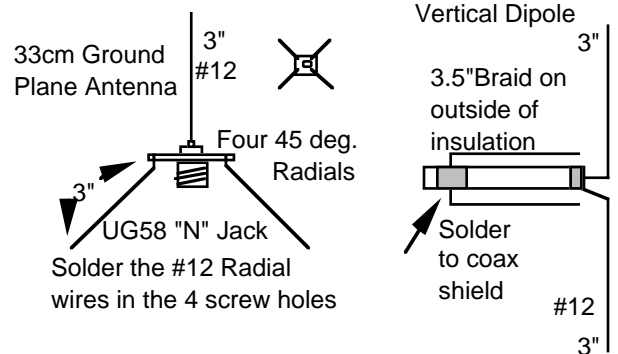
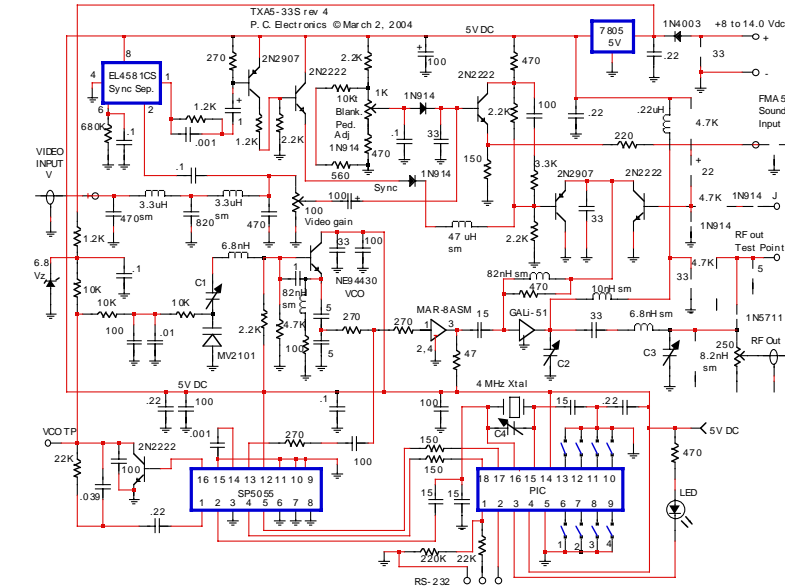
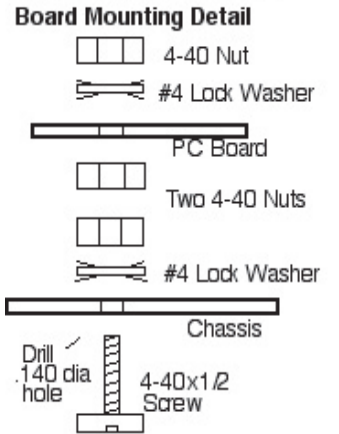

To amp or Antenna RG-174 coax - strip covering 1/4" and fold back shield. Strip center conductor 1/8". Solder center first, then the shield to ground plane. Check for short with an Ohm meter.

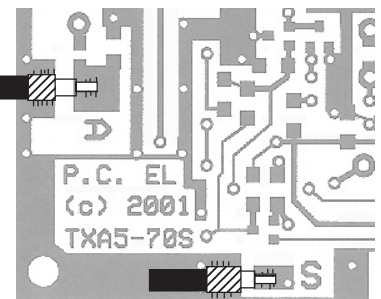

To FMA5 sound board RG174 coax

VCO TP. Factory set for 3.0 V at 923.25 MHz.
910.25 >.5 Vdc, 923.25 <.4.0 Vdc.

Final, Peak C2 & C3 at RF TP
-1 to -3Vdc. Pedestal at full CCW

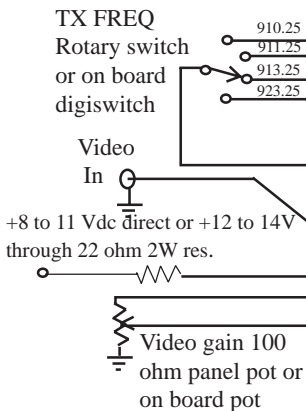

Blanking PEDestal pot Set for 60% P.E.P. To FMA5 sound board RG174 on bottom

RF power OUT pot. Set for desired P.E.P. (peak envelope power) with pedestal full CCW and no video plugged in. Then reset PED pot for .6 times P.E.P. with RF power meter in the antenna coax line if driving an amp. If running the board by itself, reset PED pot for .75 times the RF TP DC Voltage.