

TXA5-RCs ATV TRANSMITTER BOARD

The TXA5-RCs was designed for R/C model and Rocket applications, but can be used for any Amateur Radio ATV set up. The size is 1.8 x 3.7 inches and will fit in many model rockets, balloons and aircraft. The board comes wired and tested. A digiswitch and a rotary switch are provided for frequency selection. 426.25 MHz is suggested for R/C to stay away from FM and ATV repeater inputs normally found on 439.25 and 434.0 MHz. Check with local ATVers.

The video modulator contains an adjustable sync stretcher circuit that accurately sets the 70% / 30% video to sync voltage ratio to compensate for any non-linearities in the video source, exciter or add on amplifiers, regardless of average picture level changes or video gain control adjustments.

Power output is typically 1.5 Watts p.e.p. with 13.8 Vdc applied and will operate down to 8V at reduced power output. Maximum power drops to about the 1 Watt legal limit for radio control (Part 97.99) with a 12.6 V battery.

DC POWER INPUT: Power requirement is +8.0 to 14.0 Volts DC at up to 500 MA from a regulated supply or battery. Do not exceed 14.0 Volts, and make sure of supply polarity before applying. A small 1/2 to 1 Amp fast blow fuse is suggested in the + supply line. Run #22 wires directly from the battery or regulated power supply terminals to the solder pad marked "+" and the negative lead to an adjacent pad in the ground foil - not via a junction strip with other gear. The power source must be very stable as any ripple on the supply voltage shows up as noise modulation in the picture.

VIDEO INPUT: The board accepts any composite video source (1 volt peak to peak, negative going sync into 75 Ohms). This is standard from most all US cameras. Twisted #22 hook up wire can be used for runs up to 6 inches long, otherwise use small coax of any kind for up to 10 ft, or 75 Ohm coax for anything longer. The center conductor goes to the Video In pad and shield to the adjacent ground foil.

VIDEO GAIN: With a video monitor connected at solder pad M, apply video with a well lit white area that occupies at least 10% of the picture and adjust the video gain 100 Ohm pot to the point where the white area just begins to smear or white out, then back down a little. Off air with a TV set in the shack can give a false or unstable picture due to overload or multipath reflections. Have someone 100 ft or more away talk in your adjustment over the local 2 meter ATV coordination channel - 144.34 or 146.43 simplex most common.

MONITOR OUTPUT: Connect to a video monitor having a 75 Ohm resistive termination by soldering a #22 insulated wire up to 6" long, or coax if longer from the M solder pad to a video jack. The adjacent 5K pot is set to give 1V peak to peak video detected from the RF output after set up. This is a true indication of what you are transmitting.

The level may need to be adjusted if the DC applied voltage is changed or RF repeated.

AUDIO SUBCARRIER INPUT: This is optional if you also want sound. Use a short direct length of coax from the FMA5-G Sound Subcarrier Board with the center lead to the TXA5-RCs "S" solder pad on the bottom of the board and braid to the adjacent ground plane. Keep all audio leads away from RF leads as possible. With sound, the applied DC voltage must be between +10 and 14 Vdc.

RF OUTPUT: The board comes peaked by us at 434 MHz or your specified frequency, for maximum output on the sync tip - typically 1.5 Watts - then the pedestal pot set for 60% of maximum power - typically .9 Watts - into a 50 Ohm dummy load and using a regulated 13.8 Vdc power supply. It is very important for normal operation as well as preventing final transistor damage, to have a low VSWR antenna/load. No more than 10% reflected power is acceptable. Take special care with all RF cable, connectors and the antenna.

A short length of RG174 coax is soldered to the RF output "A" pad on the bottom of the board and it's shield to the adjacent ground foil. Strip the other end and connect as shown to a BNC chassis jack such as the Radio Shack RS 278-105 - do not pig tail the braid, but fold back and direct connect to the top of the shell.

BLANKING PEDISTAL SETUP: This control must be reset any time the the power supply voltage is changed more than .5 Volts or the channel is changed. Only adjust these controls with no video connected. Turn the 1K blanking pedestal pot to full counter-clockwise - max indicated power on a RF Wattmeter or dc Voltmeter on the RFout test point. Peak the 3 trimmer caps. When driving an external amplifier, a Wattmeter must be placed on the amp output. This level is the peak envelope power or sync tip power. Make a note of it's value. Next slowly rotate the blanking pedestal pot (clockwise) for 50% of the Wattmeter reading, or 70% of the output test point Voltmeter reading. Do not touch the trimmer caps after peaking and resetting the pedestal, also they cannot be used to reduce power as it could cause instability and video distortion - use an inline 50 Ohm attenuator instead.

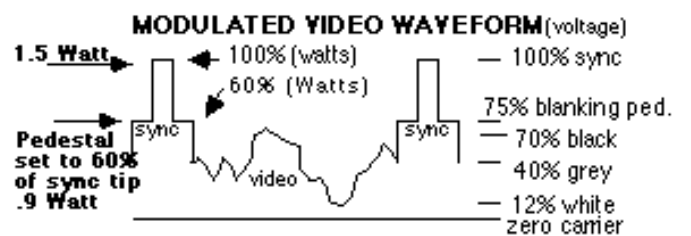

Typical RF TP scope presentation at monitor output

MOUNTING: The board must be put in a shielded enclosure to prevent stray RF from getting into the camera, R/C receiver and interfering, and to provide a heat conduction/radiation path. Do not operate without a metal to metal connection from the mounting hole nearest the final transistor to a chassis or heat sink plate of some kind or you could blow the final.

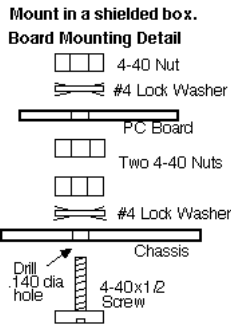

See the app note using a Hammond 1590B or 1590D die cast aluminum box. For heat conduction and grounding, mount with all 4-40-1/2" screws and nuts as illustrated, or tack solder at the four corners if you make a brass or copper enclosure. Keep power, video and sound leads away from the antenna output of any part of the RF section.

FREQUENCY CHANGE OR TUNE UP: You can solder in the supplied digiswitch, run wires to the panel mounted rotary switch, or solder a jumper to a single channel at the numbered solder pads. The 4 common frequencies used in the USA 70cm ham band starting at solder pad 1 are 426.25, 427.25, 434.0 and 439.25 MHz. Pads 5 and 6 are reserved for special orders. The frequency selected will always be the lowest numbered pad that is grounded. If all pads are open, the default is pad 1 so that you will never be out of band. The module comes peaked for 434.0 MHz, or your specified frequency using 13.8 Vdc. You should not need to readjust anything except possibly the video gain pot. If you suspect that the tuning has changed due to handling, shipping, running <12V, etc., or you wish to fine peak to another frequency follow this procedure exactly.

1. Disconnect any video and turn the pedestal pot full counter clock wise. Make sure that the low VSWR antenna or 50 Ohm dummy load is connected.
2. Referring to the board photo, connect a DC voltmeter to the RF TP - top of 1K resistor - test point and slowly peak C2 for maximum negative DC voltage. Then in like manner, peak C3 and C4.
3. Reset the pedestal pot to give 70% of what ever negative DC Voltage you read after peaking. This sets the video to sync ratio.

Trimmer cap C5 nets the frequency +/-20 kHz and need not be adjusted for the ATV mode. C1 sets the VCO to 1 V +/- .5 V at the VC TP on channel 1 - use an insulated tuning tool only. This cap should only be adjusted into a dummy load so as to not accidentally radiate out of the band.

ANTENNA: This is the most important part of your video system. It must be broadband, same polarity as used in your area, 50 Ohms and designed for the operating frequency for proper transmitter operation and best distance. The OAL 5L-70cm Yagi with it's >60 degree beamwidth cuts down multipath ghosts and is suggested for portable and public service applications - 8 dBd gain with a 31" boom end mounted. For R/C Airplanes, a 13.5" Dipole embedded in the tail fin works best - see our R/C app note on our web site. Balloons often use an upside down ground plane hanging down or an OAL 70cm Little Wheel antenna - see our balloon and rocket ATV app notes as well as Homebrew Antennas.

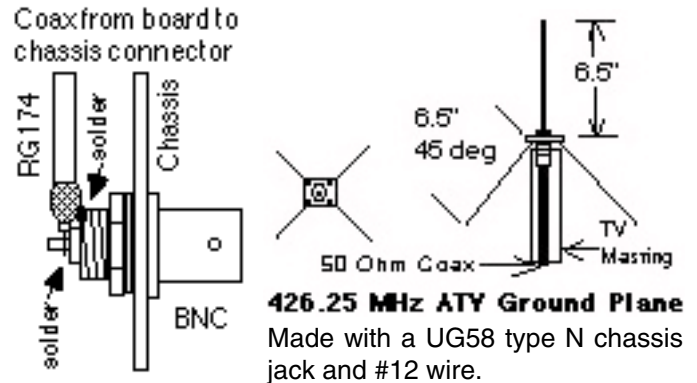

The 100 Ohm video gain pot and an LED come loose in the bag with the board. You can put them in or wire to a panel mounted pot and LED instead - LED flat side toward the PIC. The LED draws 10 mA and can be used as a transmitter on indicator. It comes on after the selected frequency is first loaded from the PIC to the synthesizer.

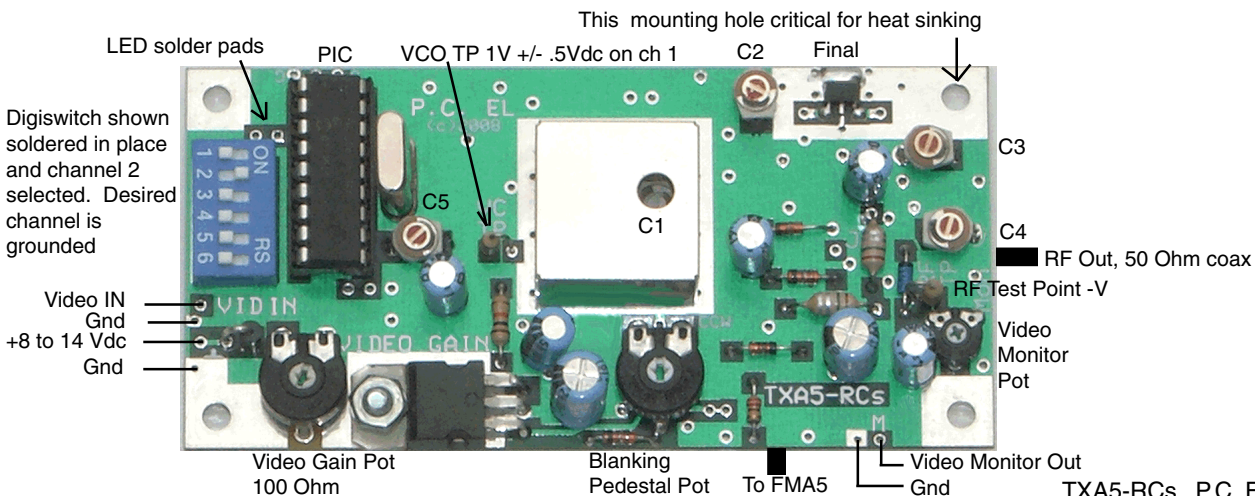

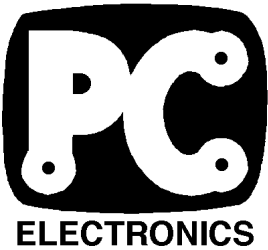

Packaged TXA5-RCs 1 Watt 70cm ATV Transmitter

Parts list for packaging the ATV transmitter:

RS part numbers = Radio shack, the alternates after are from Mouser - call: 1-800-346-6873

- 1 TXA5-RCs ATV transmitter board, P. C. Electronics
- 1 FMA5-G sound subcarrier board, P. C. Electronics
- 1 TR-1b T/R relay board, P. C. Electronics
- 1 UG-58 N chassis jack, P. C. Electronics
- 1 100 Ohm carbon pot, P. C. Electronics
- 1 Hammond 1590D die cast aluminum box, 546-1590D
- 1 10K line audio pot, RS 271-1715, 31VA401
- 1 50K mic gain pot, RS 271-1716, 31VA405
- 1 UG1094 BNC chassis jack, RS 278-105
- 1 4 pin chassis power jack, RS 274-002
- 1 4 pin power plug, RS 274-001
- 1 Inline fuse holder, RS 270-1217
- 1 1 Amp 3AG fuse, RS 270-1005, 504-AGC-1
- 3 RCA phone jack, 161-1052
- 1 Mini mic jack, 16PJ012
- 1 Sub-mini PTL jack, 16PJ100
- 3 Knob, builders choice, ME 450-6015
- 2 Toggle switch, RS 275-612, ME 108-MS550K
- 1 Lamp, RS 272-331
- 1 100 Ohm 1/4 watt resistor, RS 271-1311, 29SJ250-100
- 12 4-40x1/2" pan head screws, RS 64-3011, 5721-440-1/2
- 22 4-40 nuts, RS 64-3018, 5721-440
- 20 #4 internal tooth lock washers
- 2 #4 solder lug, 534-7311
- 4 Rubber bumpers, RS 64-2346, 517-SJ-5007BK
- Misc #22 hookup and buss wire, #18 for DC power leads

Check all parts for fit, then clean the box with isopropyl alcohol prior to painting. Spray paint the outside surfaces of the box and cover. After drying, rub on letters can be applied and then a coat of clear paint. Again, after complete drying, assemble all the parts and wire.

Board Mounting Detail

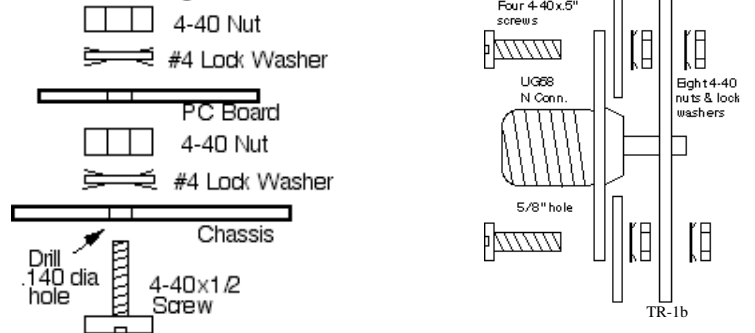

Place screw through hole in chassis, drop on lock washer or solder lug, then finger tighten the nut. Then place the PC board on the nuts and check for fit. Push down on the board near the mounting hole while tightening with a screwdriver to lock in the alignment. Then put on the final lock washer and nut.

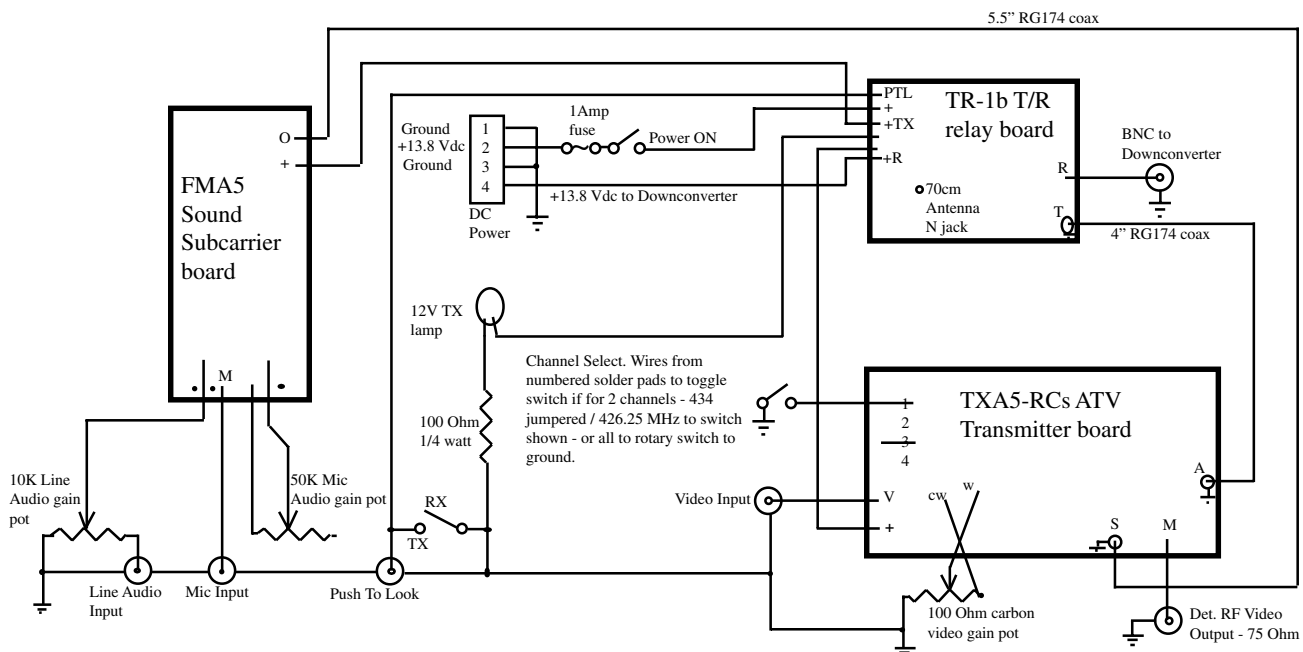

1 Watt ATV Transmitter drill drawing using a Hammond 1590D die cast aluminum box.

P.C. Electronics TXA5-RCs, FMA5-G and TR-1b boards. (c)2008

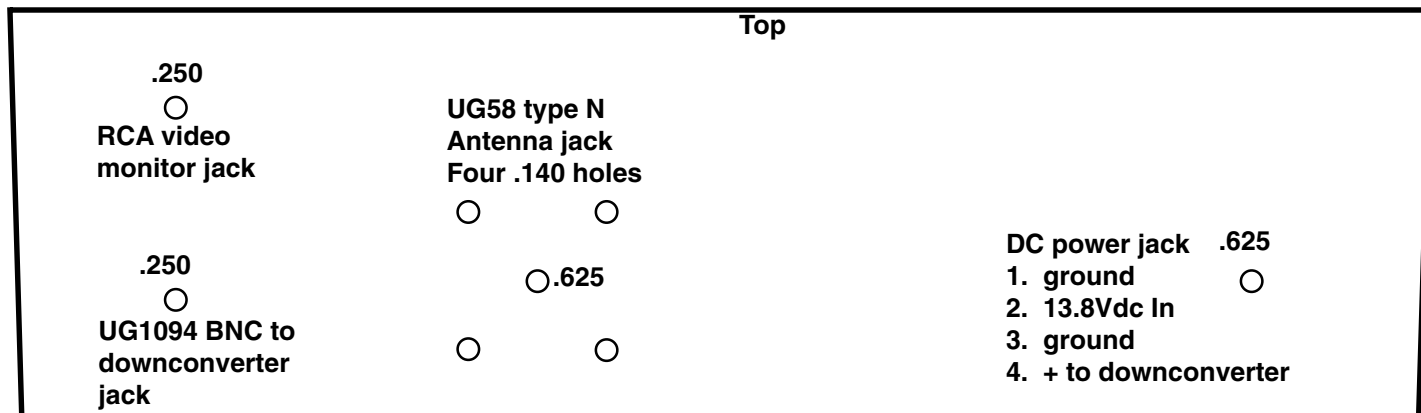
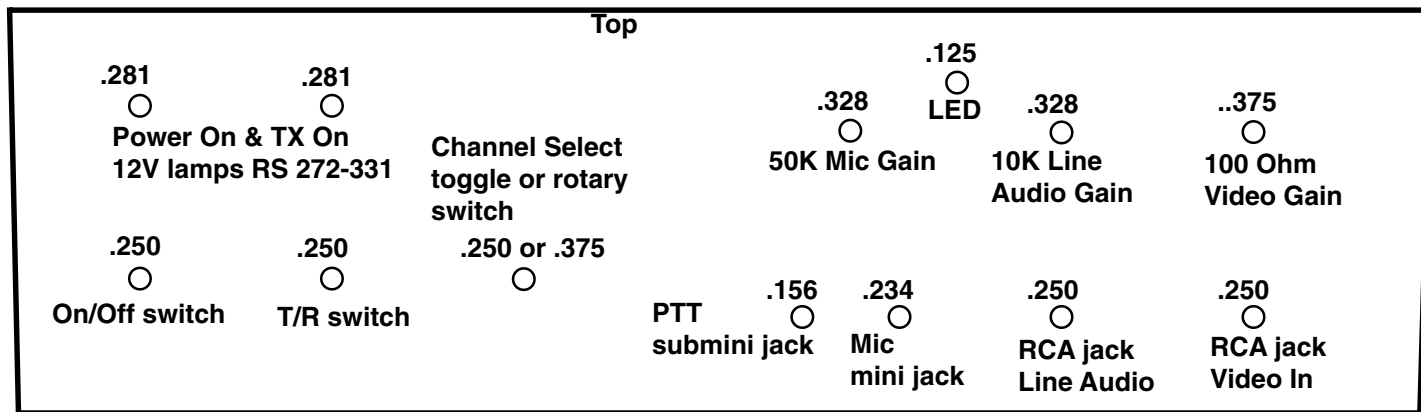
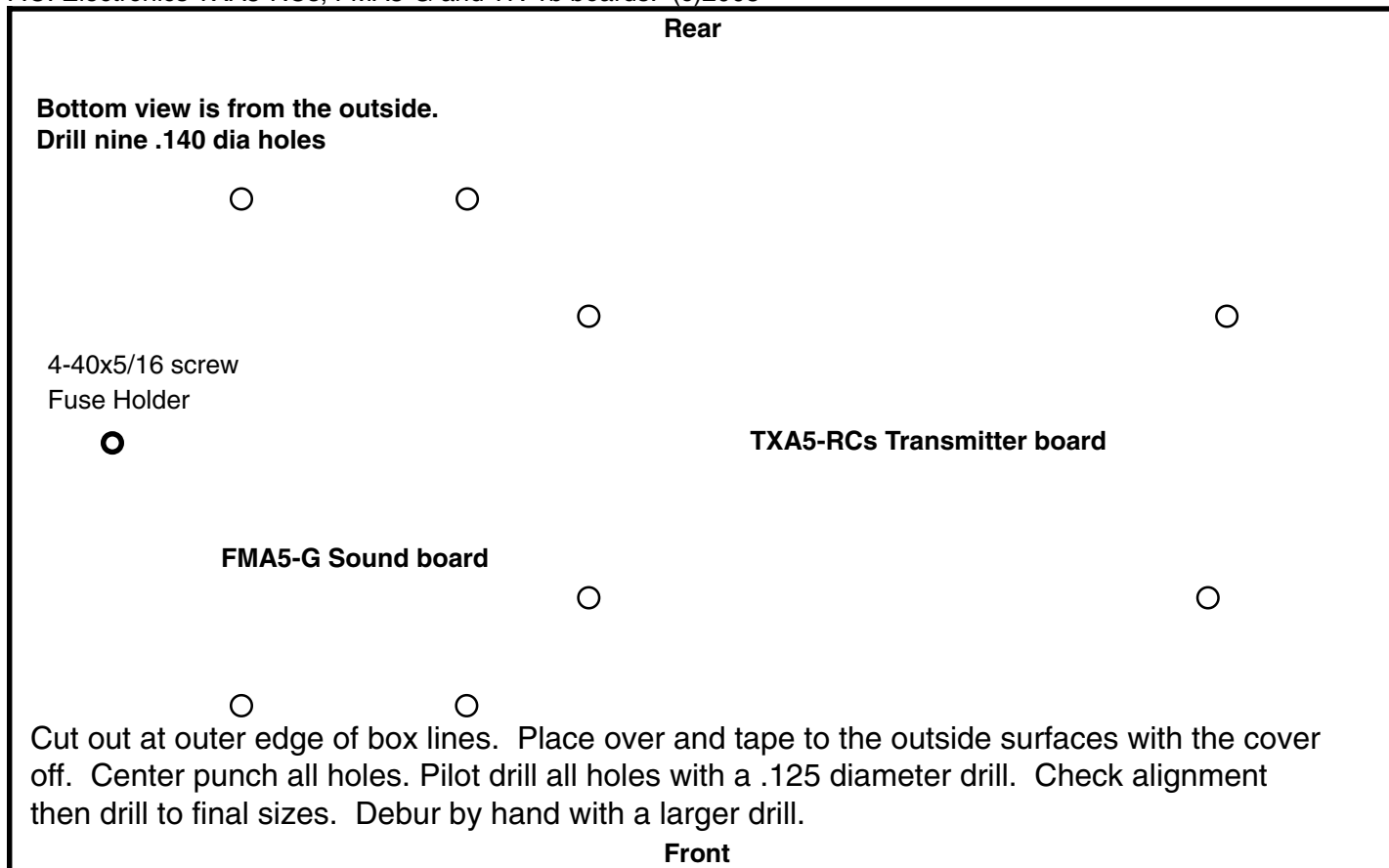

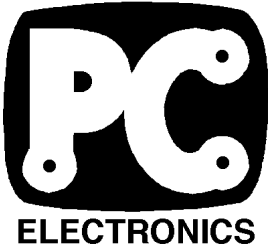

Packaging the 1W ATV Transmitter Board for R/C

One might be tempted to not package the TXA5 transmitter for placement in a R/C vehicle in order to save weight, but it may be necessary to minimize radiation from getting into the close by R/C receiver. A 72 or 75 MHz R/C receiver may not have a lot of rejection at 420 MHz, a 50 MHz R/C receiver will do best but still might not be enough depending on how close the transmitter is to the receiver and also the respective antenna separation. The die cast aluminum box shown here only takes the weight from 2 oz. to 6.5 oz but provides great shielding.

The Eagle 4591 4.5x2.5x1.2" die cast aluminum box is slightly larger than the similar size in LMB, Bud or Hammond 1590Band will accommodate the TXA5-70S or TXA5-RCb or s transmitter boards. Place the board centered in the box, center, mark and drill the four .140 holes. Drill templates are shown below for the connector ends. A BNC UG88 or gold plated SMA jack is used for the RF output with RG174 braid soldered to the shell. RG58 or RG174 coax cable with a BNC or SMA plug on the end can be made or purchased from Nema Electronics (305 893-3924) to connect to the antenna. A .001 mF feedthrough cap is used for the DC input and a RCA jack with a 33 pF disc cap for RF bypassing on the camera video input.

Before mounting the board, solder in a 1" video lead, 1" ground lead and 1.5" DC power lead to the respective board solder pads. Finger tighten the 4-40x1/2 screws, lock washer and double nuts. Mount the board, and while holding the board down in place with your hand, tighten the screw heads. Then put the lock washer and

nuts to hold the board. Mount the RCA jack and bend the ground solder tab so that the 33 pF disc cap has practically no leads when attached. Connect and solder the video and ground leads to the RCA Jack, then the DC power lead to the feed thru cap. Mount the BNC or SMA jack. Cut the RG174 coax to 2", strip the outer insulation off to 1/4" and fold it back. Strip the center conductor 1/8" and carefully solder to the connector as shown. This is necessary to prevent a VSWR current flowing all through the inside of the box. Verify with an Ohm meter that the coax is not shorted - >4K to ground.

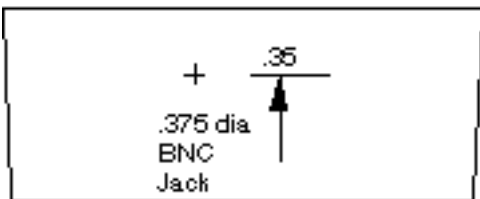
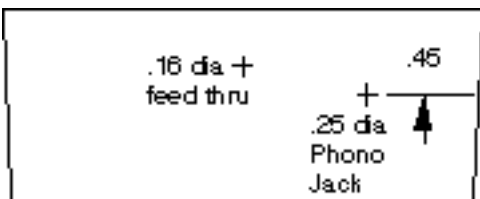
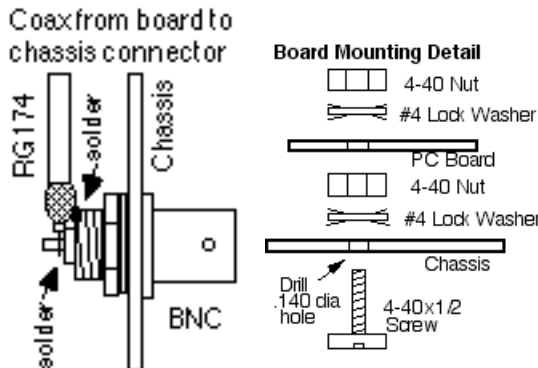

Cut out drill template and center punch indicated hole locations. Check .35" and .45" dimensions from open edge with cover removed before drilling.

- Parts List;
 TXA5-RCb ATV TX, P. C. Electronics
 Hammond 1590B box, Mouser Electronics
 .001 Feedthru cap, P. C. Electronics
 RCA Jack, Mouser 161-1052
 BNC Jack, Radio Shack 278-105
 Mouser call 800-346-6873

Video In
 RCA jack

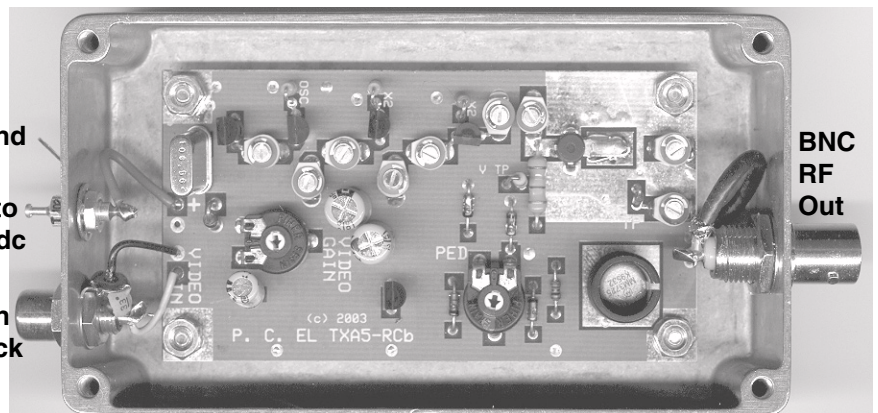

Example TXA5-RCb shown in a die cast aluminum box

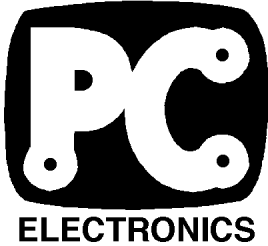

Driving the PA5 20 Watt Amplifier from the 1.5 Watt TXA5-RCs ATV Transmitter Board

There are many applications where having the flexibility of easily switching from 1 Watt to 20 Watts without having a completely separate ATV transmitter system is desirable. If 1 Watt is not enough for a public service event, or in a long range balloon, rocket or R/C application, but there are other times when you don't need 20 Watts, then you can drive the PA5 20 Watt peak envelope power amplifier through a RF attenuator.

I often get asked if the PA5 20 watt amp can be driven by the TXA5-RCs just by detuning C2,3 and 4. No, the board could become unstable and you had better be able to accurately measure the TXA5-RCs output power. If you don't verify before connecting to the PA5 that the power is less than the 200 milliwatt's, you will blow the first stage of the power module. Most do not have a RF power meter that will accurately go down that far.

Secondly, the 20 watt power module in the PA5 only takes about 20 mw to give the 20 Watts out at 13.8 Vdc applied. The TXA5-RCs may not want to be turned down that far and still be able to set the pedestal as well as get good stable video.

If you want to switch back and forth between 1W and 20Wpep the easiest answer is to put a good, known, 15 or 20 dB 2 watt inline attenuator in the coax line between the TXA5-RCs and PA5. Mini-Circuits Lab makes a 50 Ohm 2 watt inline coax attenuator with SMA connectors, model S20W2, for \$30 (718-934-4500 www.minicircuits.com).

You can also build a Pi attenuator using non-inductive resistors (no wire wounds), but the wire leads are very significant inductors, especially the 62 Ohm resistor. The TXA5-RC side 62 Ohm needs to be a 2 Watt as it dissipates most of the power.

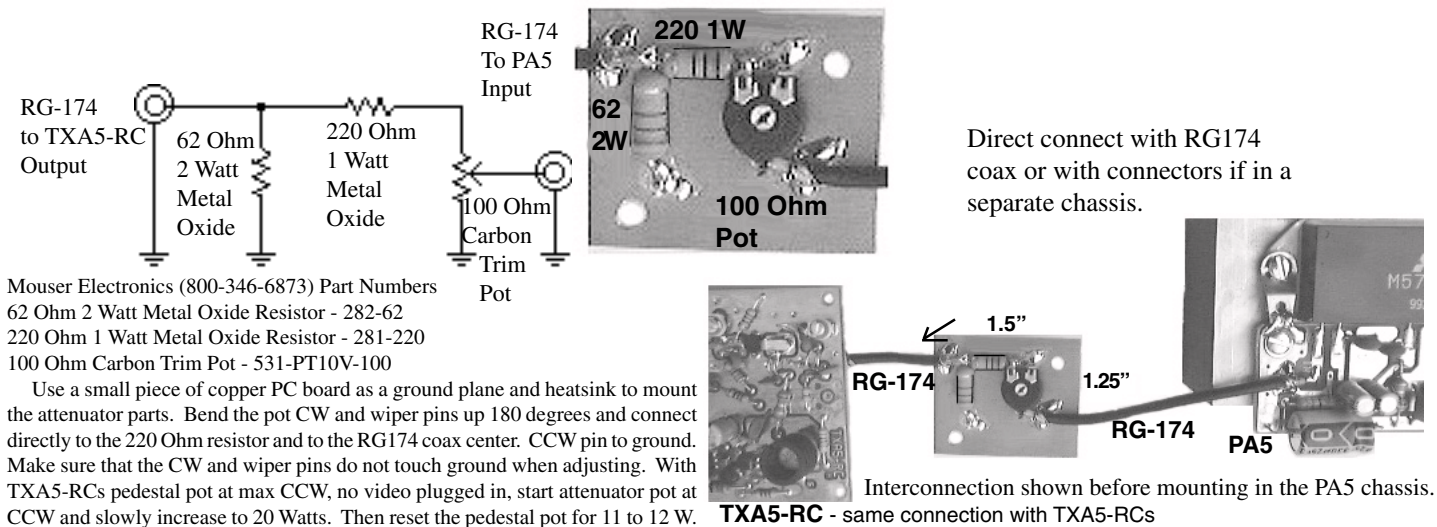

The attenuator shown varies from about 18 dB to 33 dB with the pot, and gave 25 Wpep max to 1 Wpep minimum when driven with 1 Wpep from the TXA5-RCs. Construct on a 1.5 x 1.25" piece of copper PC board. Note there are practically no leads so as to minimize inductance. Two holes are drilled to mount on the chassis with screws to help pull away some of the heat. Check for shorts before applying power with an Ohm meter.

Another solution, if you have room, is to coil up 80 feet of RG174 coax to give the 20 dB of attenuation at 420 MHz between the two modules. RG-174 has 25 dB/100 ft. of insertion loss at 420 MHz or 1 dB/4 feet. The coax length can then be reduced little by little until the full 20 watts p.e.p. is reached out of the PA5. No matter which method of attenuation you use, you would need to have a good RF power meter in the PA5 output to verify that the peak envelope power does not exceed 20 Watts and to reset the TXA5-RCs pedestal pot for 60% of what ever the p.e.p. reading is. The PA5 will put out more p.e.p., some as high as 30 watts, but the video linearity and color burst start to degrade and the signal strength between 20 and 30 watts is hardly noticeable at the receive end.