

## Videolynx Model VM-70X

19910 Bramble Bush Dr Gaithersburg, MD 20879  
240-602-1082 Voice www.transmitvideo.com

### 70CM, 4W Synthesized Video Audio Transmitter

ONLY FOR AMATEUR RADIO USE



### Overview

The Videolynx VM-70X is a very high performance amateur radio ATV transmitter module. The VM-70X is designed as a module that can be integrated as a standalone or sub-circuit for various amateur radio projects. The circuitry is mounted on an aluminum plate. This plate serves as a heat sink for low power-short duty cycle operation (Output less than 0.5W CW). For high power or continuous duty cycle operation (output >0.5W) the VM-70X needs additional heat sinking, therefore the VM-70X will need to be mounted to an external heat sink.

### Frequency control

Frequency control is provided by means of a digital integer-N, phase locked loop. Dual PLL's provide a frequency locked video and audio carrier. Per customer special requests, the VM-70X can be programmed for operation outside the US, for PAL and SECAM video standards. The transmit frequency is selected via a four position dip-switch. The VM-70X comes preset with four standard US, 70cm ATV frequencies. At least 3 of the preset frequencies correspond to cable channel, CH 58, 59 and 60.

## Modulation

Internally, Video modulation is controlled via a 12 bit digitally controlled DAC-digital to analog converter. An embedded software algorithm controls the modulation depth and pre-distortion level to deliver an ultra clean video signal to the final RF amplifier. The result is a near broadcast quality signal with minimum RF distortion and zero “sync buzz”. A built in video and audio test signal generator is provided for convenience.

## RF output

RF power output is controlled via a user adjustable analog potentiometer. The RF power output can be controlled from near zero RF output, to about 5W CW maximum. The current draw varies with the power level selected. The VM-70X is set for 0.5W output at the factory. The user may change this to the desired level.

## Heat sink

Videolynx recommends that the VM-70X be mounted to an external heat sink at all times. However, if transmitting without an external heat sink, limit the power to no more than 0.5W output and avoid long key down periods. A good rule of thumb to follow is if the aluminum plate is too warm to the touch, then its time to key down. When provided with a sufficient external heat sink, the VM-70X can be used for long key down operation. Lab experiments have shown that by placing a small fan about 1” away from the plate produces sufficient heat removal for long key down operation at high power.

## Application Diagram

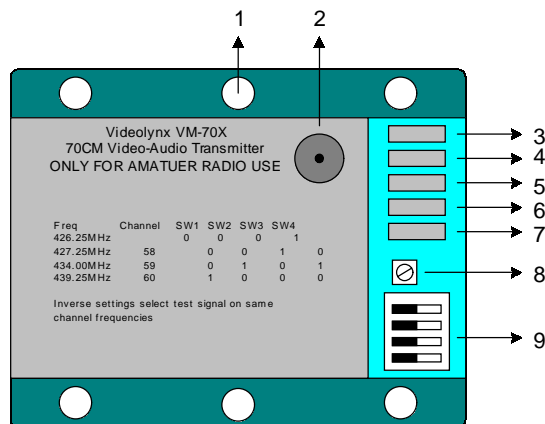

Fig 1

1. Mounting holes (X6) – Hole diameter 0.125. Use the six holes to mount the VM-70X to an external heat sink. Use silicon thermal grease!
2. Antenna connector – SMA antenna connector, 50-ohm impedance. Always connect to a load before transmitting.
3. External 12-13.5V in – Positive Solder terminal
4. Negative Solder terminal (Power ground terminal)
5. Audio In, Solder terminal – Line level audio in. Connect an audio signal (line level, 200 – 250mV RMS)
6. Ground Solder terminal – Audio / Video Ground terminal
7. Video In, Solder terminal– Composite NTSC video in (1V P-P)
8. RF output control – Full CCW for minimum RF output – Full CW for maximum RF output
9. Dip-switch frequency select. See Table 1 for settings

### Video Connection

Supply a composite video signal between this terminal and GND. See Fig.2 on how to build a video cable with a female RCA connector.

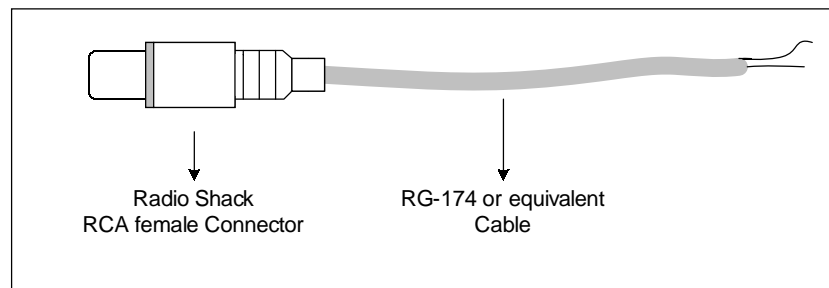

Fig.2

### Audio Connection Terminal

Supply a line level (150mV –250mV) RMS audio signal to this terminal and GND. See Fig.2 on how to build a simple RCA female audio cable.

See Fig.3 on how to supply an adjustable audio signal to this terminal

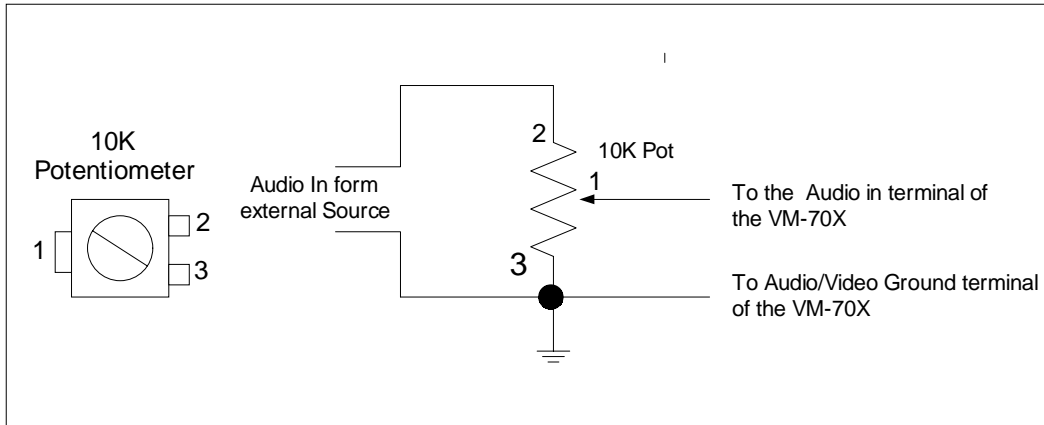

Fig.3

## Antenna

- Antenna performance is crucial for the usable range of the any transmitting system. This is especially true for video transmitters, since the RF energy is spread across a large frequency span. High gain antennas specifically designed for ATV should be used as opposed to narrow band weak signal antennas. Remember, antenna bandwidth is critical. Ensure that the transmitting antenna has a wide enough bandwidth centered at the transmitting frequency.
- Some antenna manufactures and distributors we recommend:
  - 1) PC Electronics – Arcadia California 626-447-4565
  - 2) M2 antenna – 559-432-8873
- For semi-portable operation, the 432 HO loop, manufactured by M2 antenna performs extremely well.
- See Fig.4 for a simple homebrew ground plane antenna.
- The key to attaining best range is to use high gain antennas for both receive and transmit. Use low loss coax to keep losses at a minimum

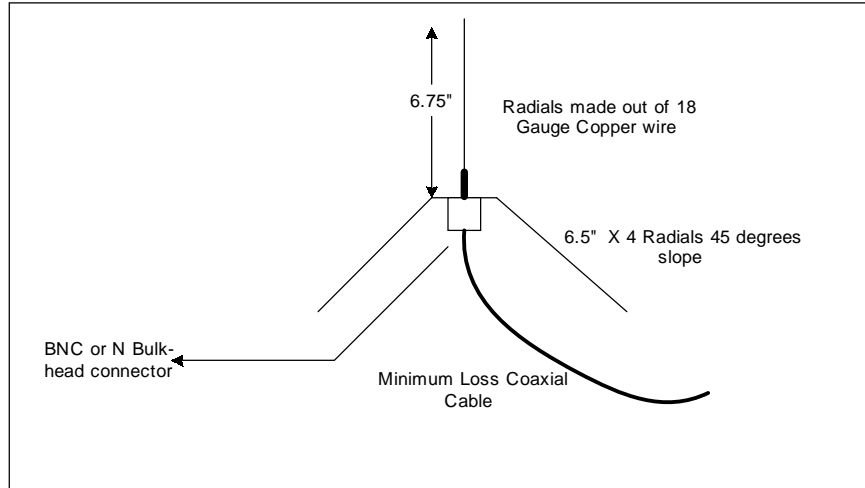

Fig. 4

### Frequency Selection

Frequency	Channel	SW1	SW2	SW3	SW4	Function
426.25MHz		0	1	1	1	Normal Operation
427.25MHz	Cable 58	1	0	1	1	Normal Operation
434.00MHz	Cable 59	1	1	0	1	Normal Operation
439.25MHz	Cable 60	1	1	1	0	Normal Operation
426.25MHz		1	0	0	0	Test signal Enabled
427.25MHz	Cable 58	0	1	0	0	Test signal Enabled
434.00MHz	Cable 59	0	0	1	0	Test signal Enabled
439.25MHz	Cable 60	0	0	0	1	Test signal Enabled
All other settings are reserved and will disable the RF carrier						

Table 1

### RF power adjustment:

Use only the required amount of RF output to minimize heating. Measure the current draw with a power meter, and do not exceed 1.5A when adjusting the RF power output

## Heat Sink

Videolynx recommends mounting the VM-70X to an external heat sink at all times. An inexpensive but effective heat sink can be made using a computer type CPU heat sink/fan combination. Lab experiments have shown that a small fan placed close to the VM-70X provides sufficient cooling for safe operation. The VM-70X is designed as an OEM type module. Its up to the user to provide a sufficient means to remove dissipated heat.

## Electrical Characteristics

RF Power output	0 to 5W Maximum, CW
RF termination Impedance	50 ohms
Audio Sub-carrier	4.5MHz at 25 KHz deviation
Spurious Output	Better than -40dBc
Carrier phase noise	-75dBc/Hz at 500bKHz offset
DC power in	12 – 13.5V Max (+/-100mV)
Current Draw	Max 2.2A
Frequency Control	XTAL reference to 4MHz
Frequency Stability	+/- 40PPM
Video in	Composite Video NTSC 1V P-P
Video Input Impedance	75ohms internally terminated
Automatic Clip Level	110 IRE
Audio in	Line Level 200 -250mV RMS
Audio Input impedance	50K
Audio Deviation	+/- 25 KHz at 202mV RMS, 1 KHz Sine Wave
Audio Distortion	Better than 2% THD at 1 KHz
Operating temperature	-20 to +65 degrees Celsius
Size	2.35"W X 2.8"L X 0.75"H